



In partnership with



Jochen Haenisch
Director for Defense and Aeronautics
Jotne EPM Technology

<http://standardsdays.afnet.fr> - AFNeT Standards Days 2020 : 6 & 7 October 2020 – team@afnet.fr

Interoperability of Structural Analysis models based on STEP AP209

Jotne



AFNeT Standards Days 2020

2020-10-06

Contents

- A typical AP209 use case
- Scope of AP209
- CAE-IF
- AP209 PhD thesis
- Edition 3 – standardization and recommendations
- Other AP209 developments
 - A potential edition 4
 - Use cases

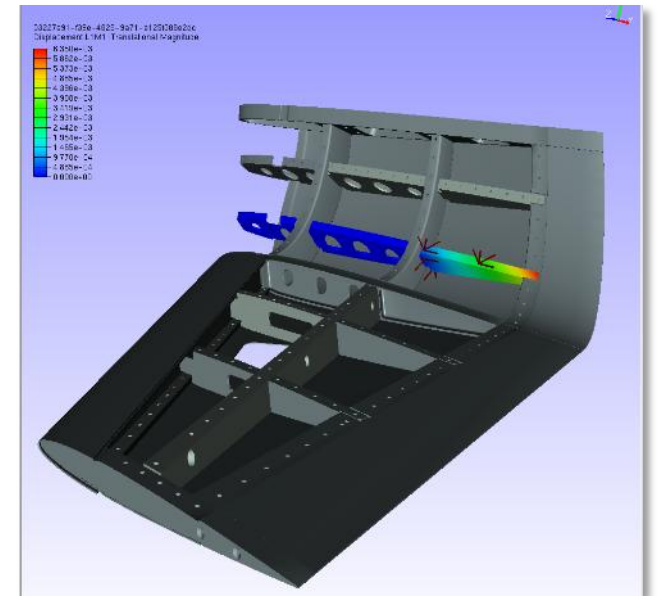
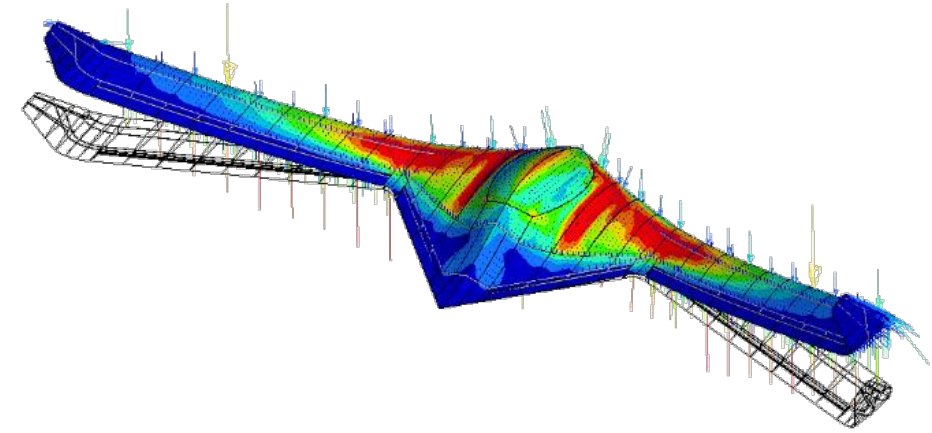

Assemble, integrate and test (AIT) spacecraft

- **Spacecraft development:**

- Planning
- Design
- Analysis
- Assembly
- Integration
- Testing



Lots of data

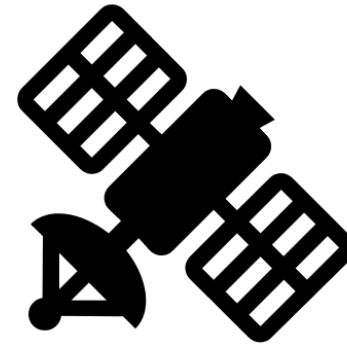

- **Challenge :**

- Consistency among different models of the same product
- Traceability of data from different **domains**, from different **sources**, in different **formats**



The ESA DEFINE project

- **Objective:** *Multidisciplinary 3D digital models for AIT environment*
 - Develop a platform for managing data from design, analysis, testing and PLM.
 - The platform shall be based on the standard representation of **ISO 10303 STEP**.
- **Typical use cases:**

Compare geometric shapes from different applications

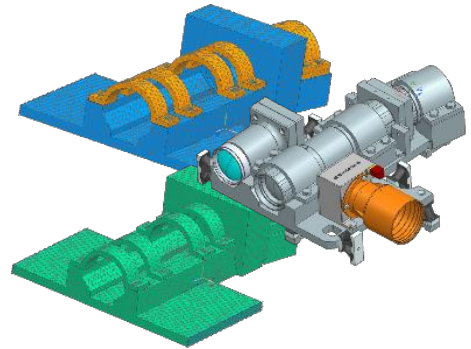

Compare clouds of points with 3D models

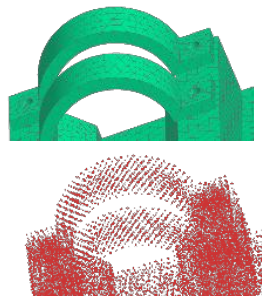

Visualize sensors on 3D models

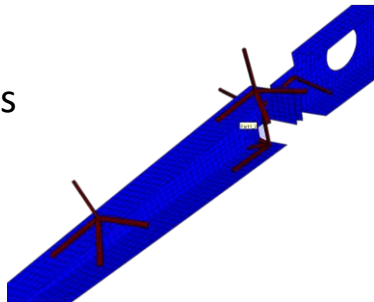

Correlate/compare sensor results and analysis results

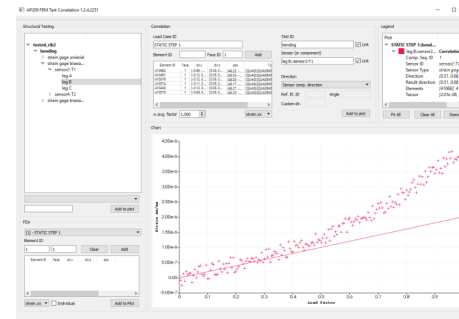

Map thermal raster images on to meshes and shapes

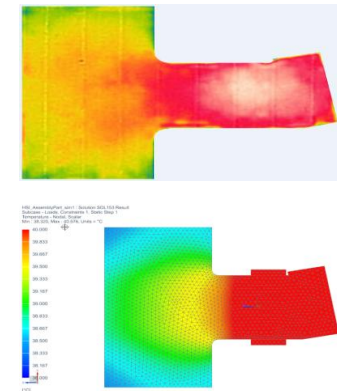

++

DEFINE - Development

- **Done:**

- Define the applications and formats to be supported
- Define the data within the formats to be supported
- Define the mapping between the formats and ISO 10303-209
- Define cross-model relations for models of different domains

- **Ongoing:**

- Develop converters between the formats and ISO 10303-209

- **To do:**

- Integrate converters in SDM application
- Develop user functionality for import processes

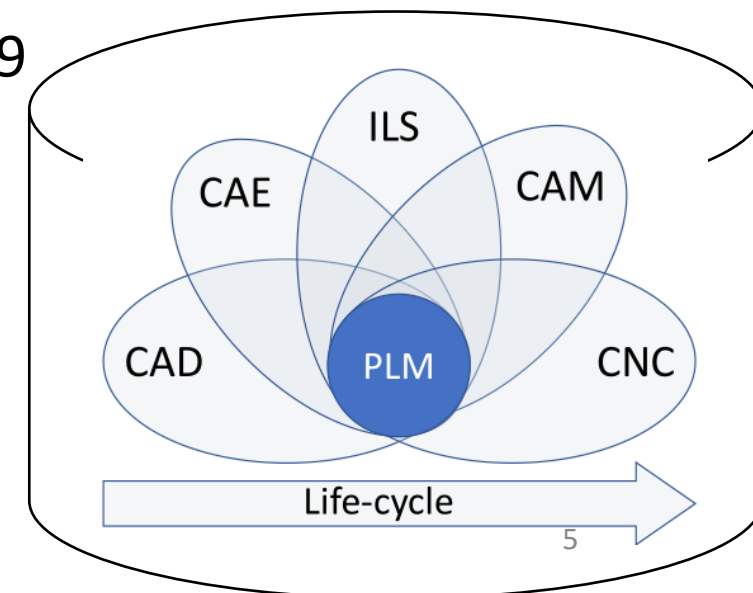
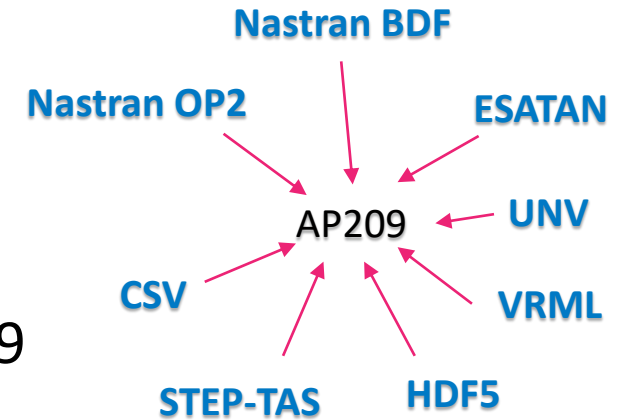

DEFINE - Mapping to AP209

AP209

Nastran BDF

```

CHBDYE  EID  EID2  SIDE
CHBDYE  54154 45624 2
CHBDYE  54155 45625 1
CHBDYE  54156 45626 4

      EID  PCONV      Tai
CONV    54154 22      0  87126
CONV    54155 22      0  87126
CONV    54156 22      0  87126

PCONV   PCONID  MID
        22      3

      MID      H
MAT4    3      60.0
    
```

Nastran OP2

| Word | Name | Type | Description |
|--------------|----------|------|---|
| 4 | SUBCASE | I | Subcase or Random identification number |
| TCODE,1 = 1 | | | Sort 1 |
| ACODE,4 = 01 | | | Statics |
| 5 | LSDVMN | I | Load set number |
| 6 | UNDEF(2) | None | |
| ACODE,4 = 02 | | | Real Eigenvalues |
| 5 | MODE | I | Mode Number |
| 6 | EIGN | RS | Eigenvalue |
| 7 | MODECYCL | RS | Mode or Cycle |

Cloud of points



Sensor definitions

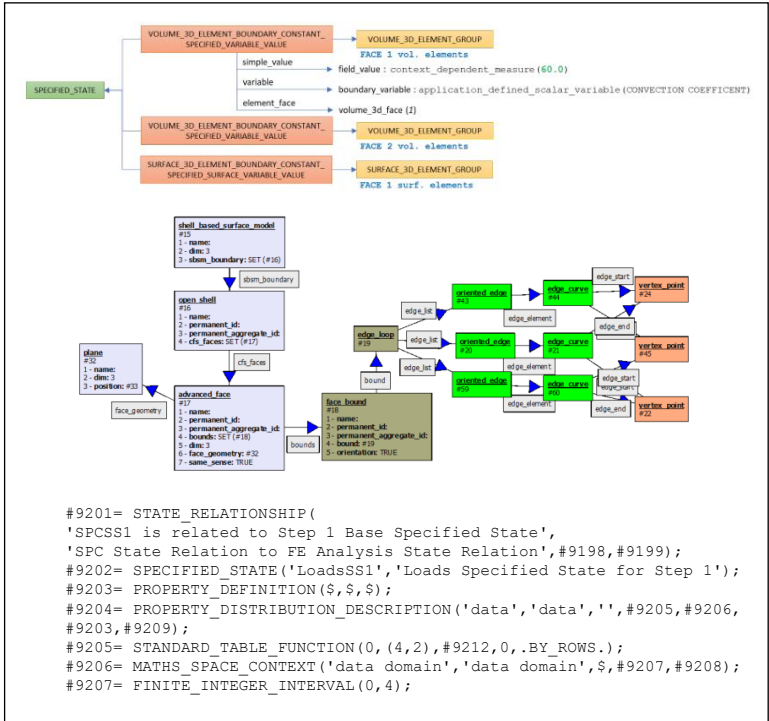
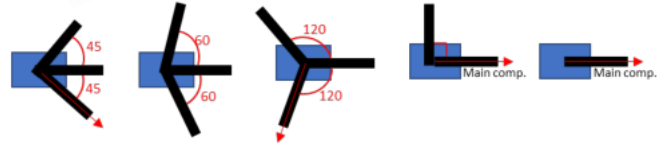

Thermal raster image projection

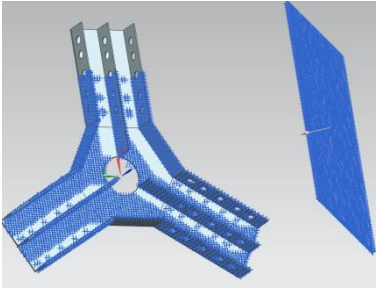

STEP-TAS

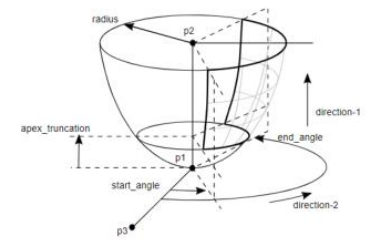

Test data .UNV

```

55
Modal processing
Analysis data universal file, Test.Lab project "Tedy_Hydra_2017"
24-08-2020 11:00:28
MODE NO. 1, FREQUENCY 26.309503(Hz), DAMPING 0.005108
10002      1      8      13
1          3      2      8      5      3
2          6      1      1
-8.44397e-01 1.65307e+02 0.00000e+00 3.30615e+02 5.46531e+04
2.79170e+02
10010
-2.15555e-02 2.60107e-04 1.59975e-03 -1.12287e-03 1.56752e-03 -
9.91807e-04
10011
-2.33186e-02 7.38849e-04 1.72283e-03 -1.11238e-03 -1.32503e-02 -
1.22265e-04
10012
    
```

Test data .csv

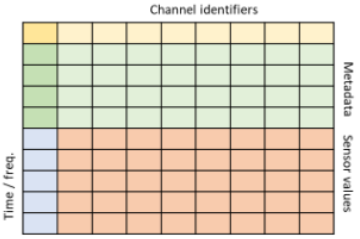

ESATAN results

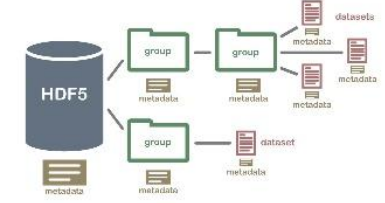

DEFINE - ISO 10303-209 Repository

The project will augment AP209 repository to support the new engineering domains.

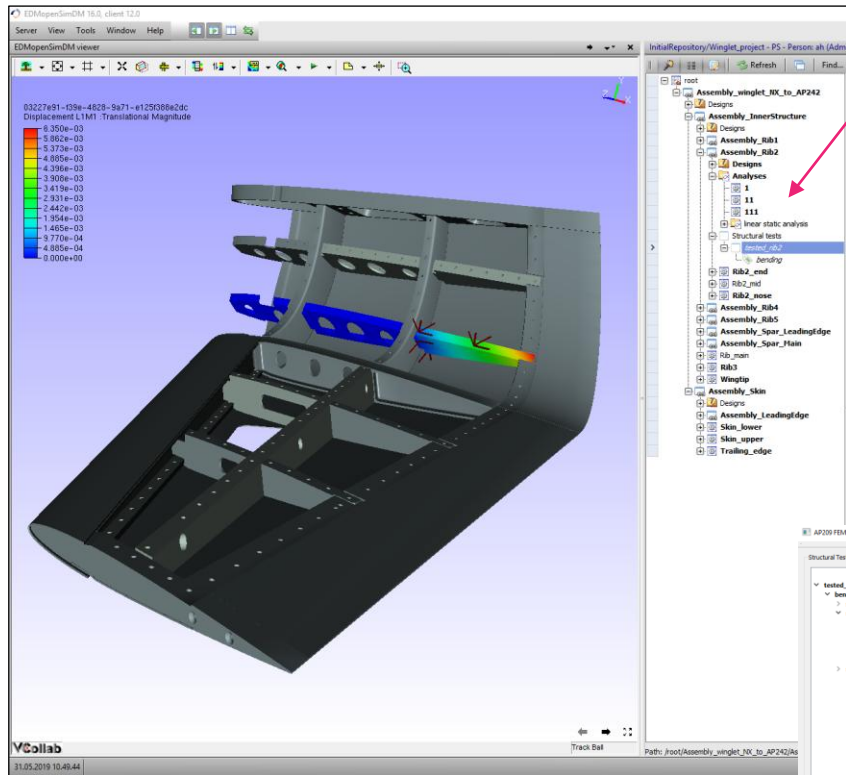

Project and product breakdown structure

- Supported formats are converted to AP209; with the use of special import functions, the model's content is linked to relevant related data objects.
- Unsupported formats are linked in on file level.

Data processing tools

- Correlation of strain gauge data and structural FEM results exists:

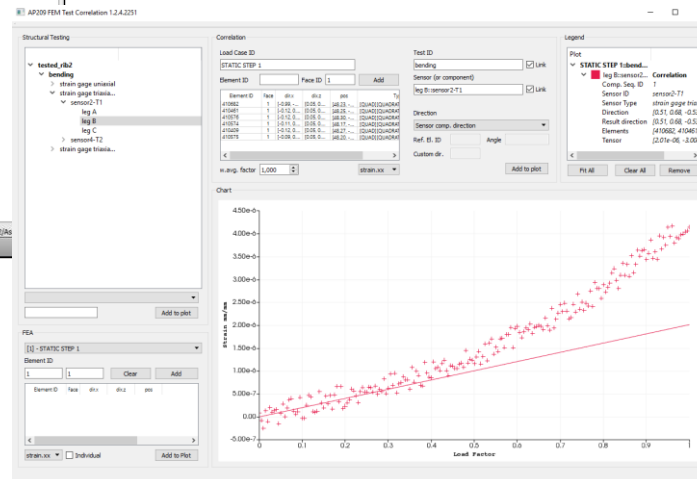

- Additional tools to be developed:

- Projection of thermal images onto 3D models and meshes
- Generation of nodal temperature loads
- Support correlation of data from other sensor types and analysis types

AP209 edition 2: Scope (1/2)

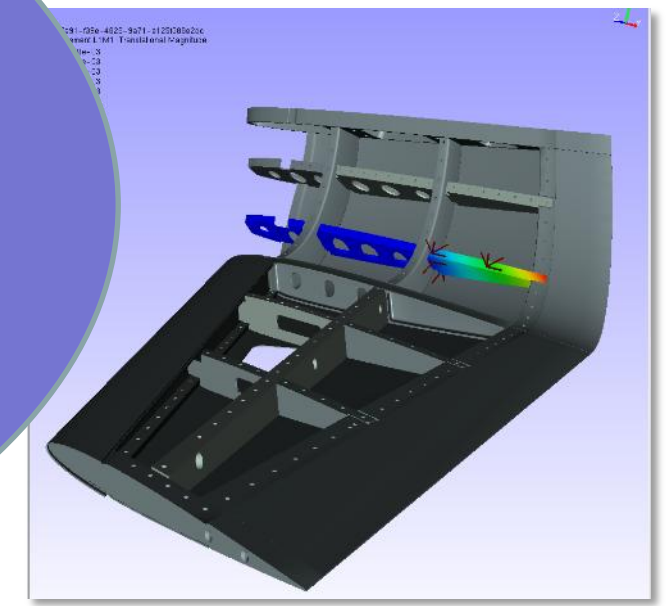
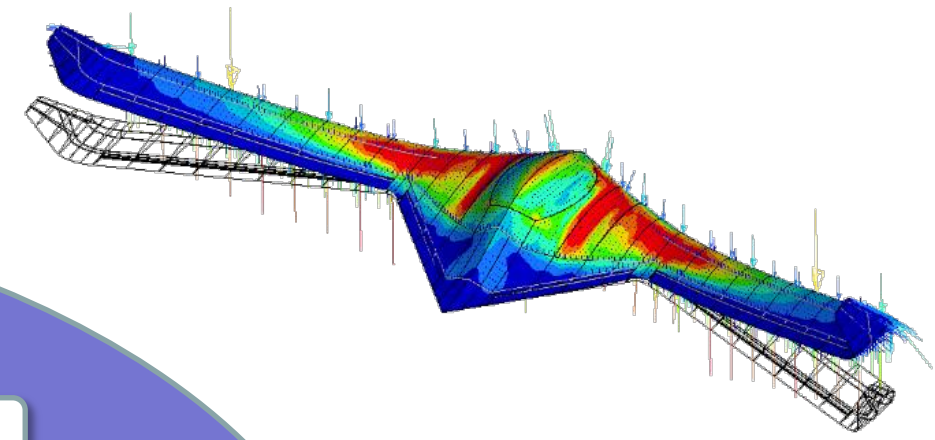
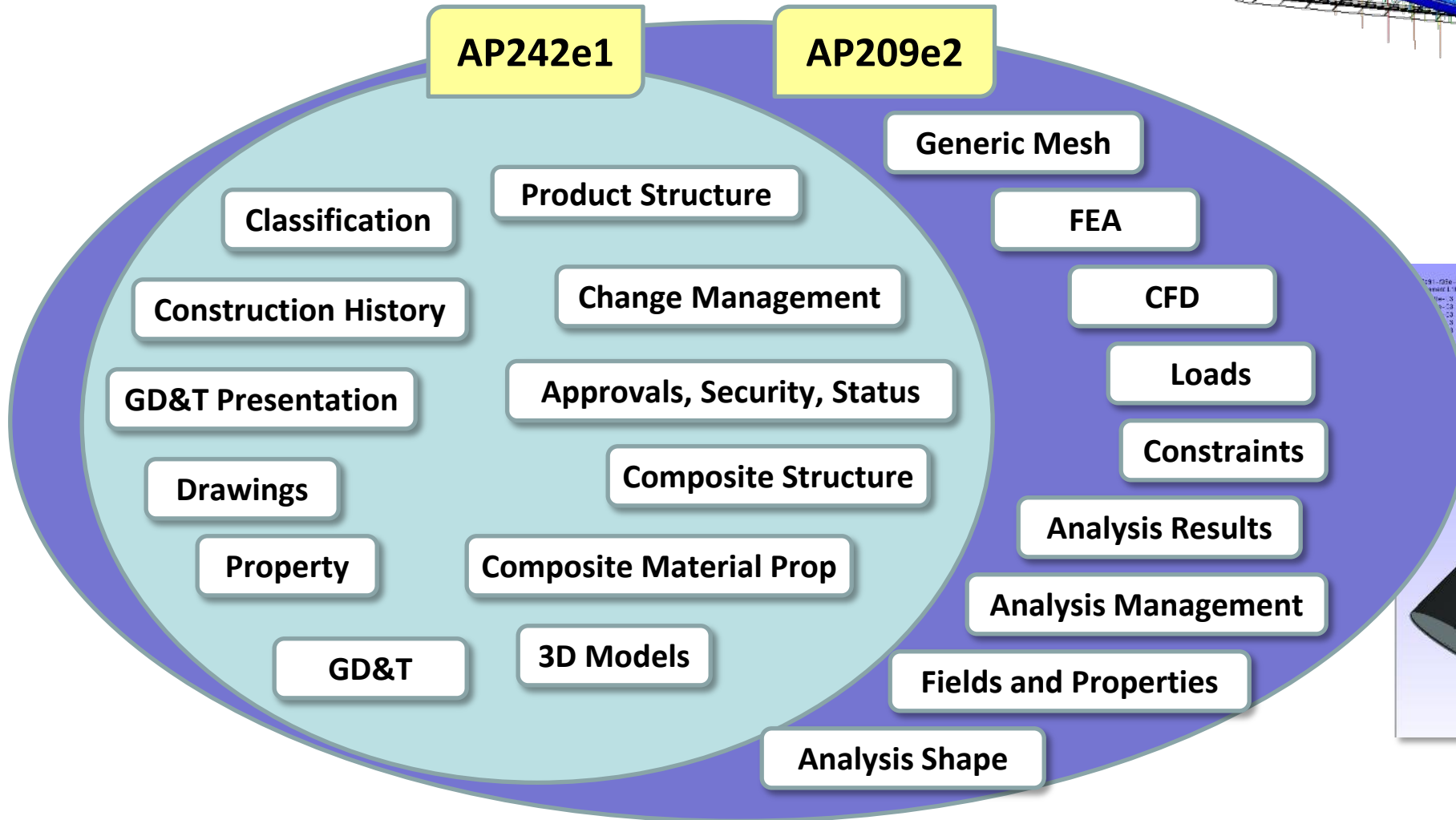

AP209 edition 2: Scope (2/2)

Analysis Discipline Product Definitions

- Finite Element Analysis (FEA)
- Computational Fluid Dynamics (CFD)
- Generic Structured/ Unstructured Mesh and Meshless Numerical Analyses
- Kinematic Analyses
- Discrete and Continuous Scalar, Vector and Tensor Fields (properties, loads, results)
- Analysis Reports

AP242-Based Design Discipline Product Definitions

- Part, product, document identification and management (PLM)
- Activity/Work Management
- Product Structure (Assemblies)
- GD&T/PMI Information
- Presentation/Draughting

3D/2D Shape Representations

- AP242 Commonality
 - Advanced B-Representation
 - Faceted B-Representation
 - Manifold Surfaces With Topology
 - Wireframe & Surface without Topology
 - Wireframe Geometry with Topology
 - Tessellated Shape Representation
 - Composite Constituent Shape Representations

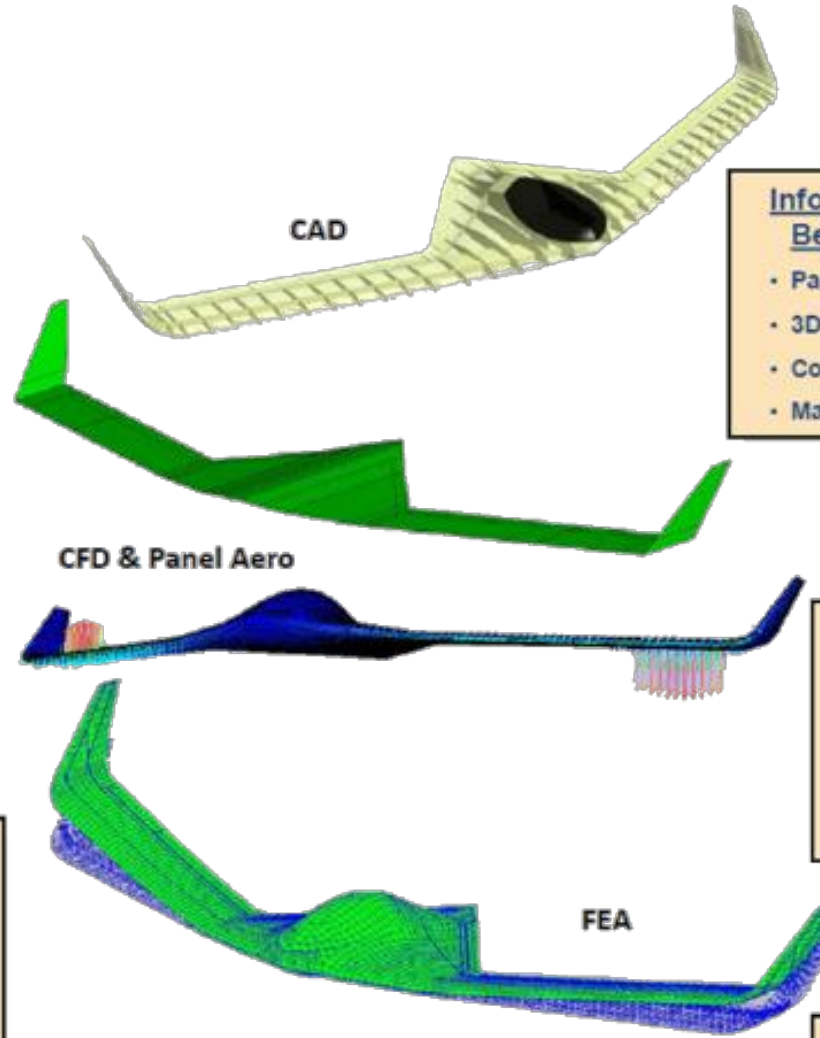

Information Associatively Shared Between Analysis & Design

- Part Definitions
- 3D Shape Representations
- Composite Constituents
- Material Specifications & Properties

Composite Constituents

- Ply Boundaries, Surfaces and Volumes
- Laminate Stacking Tables
- Composite Assemblies
- Reinforcement Orientations

Material Specifications & Properties

- Composites
- Homogeneous (metallics)

AP209 edition 2: Implementation benchmarks

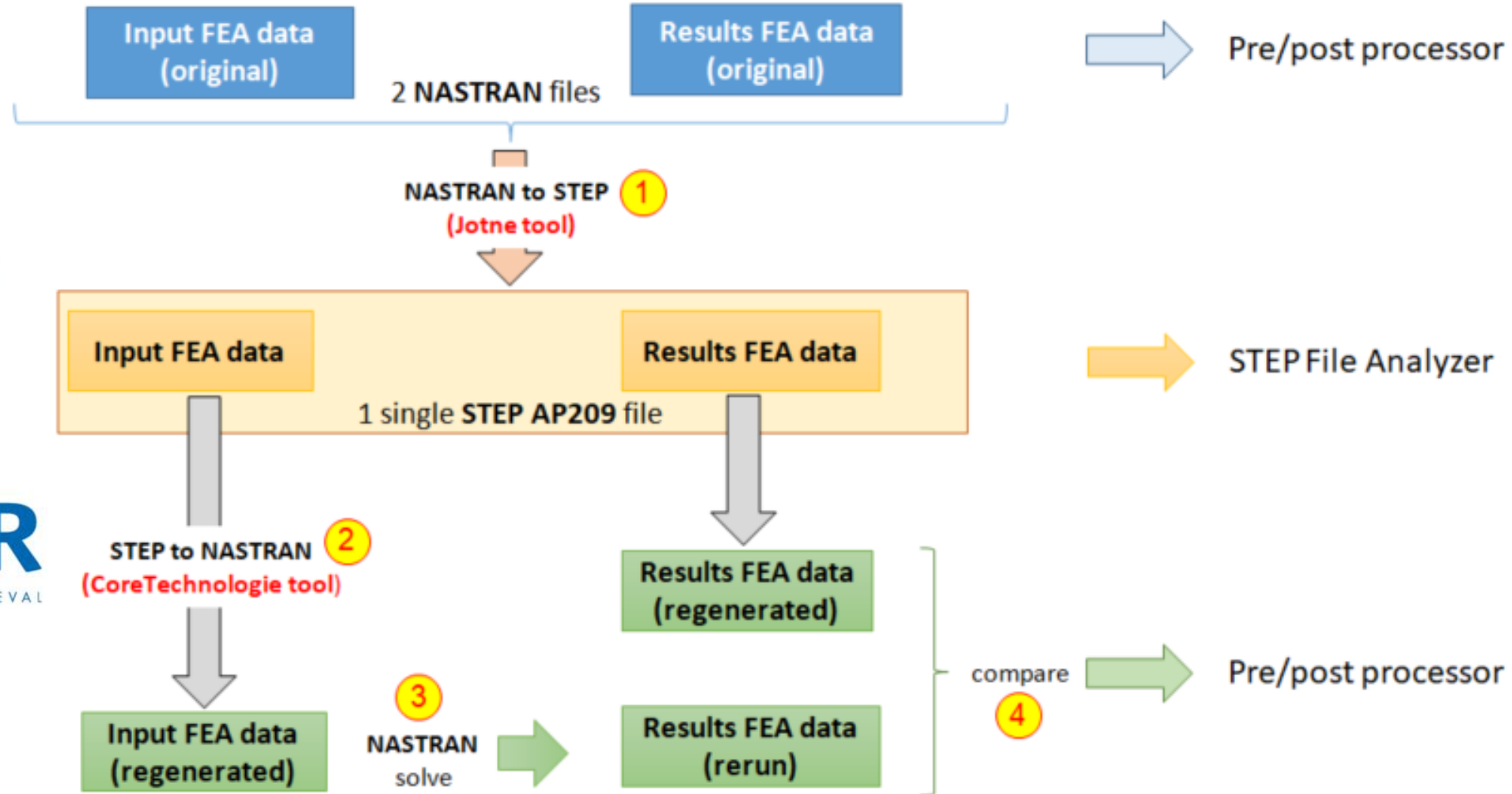

©LOTAR 2018 | All rights reserved



Using AP209 for simulation and structural test data

Design CAD

Some related SW



Analysis FEM



Manufacturing



Sensor data

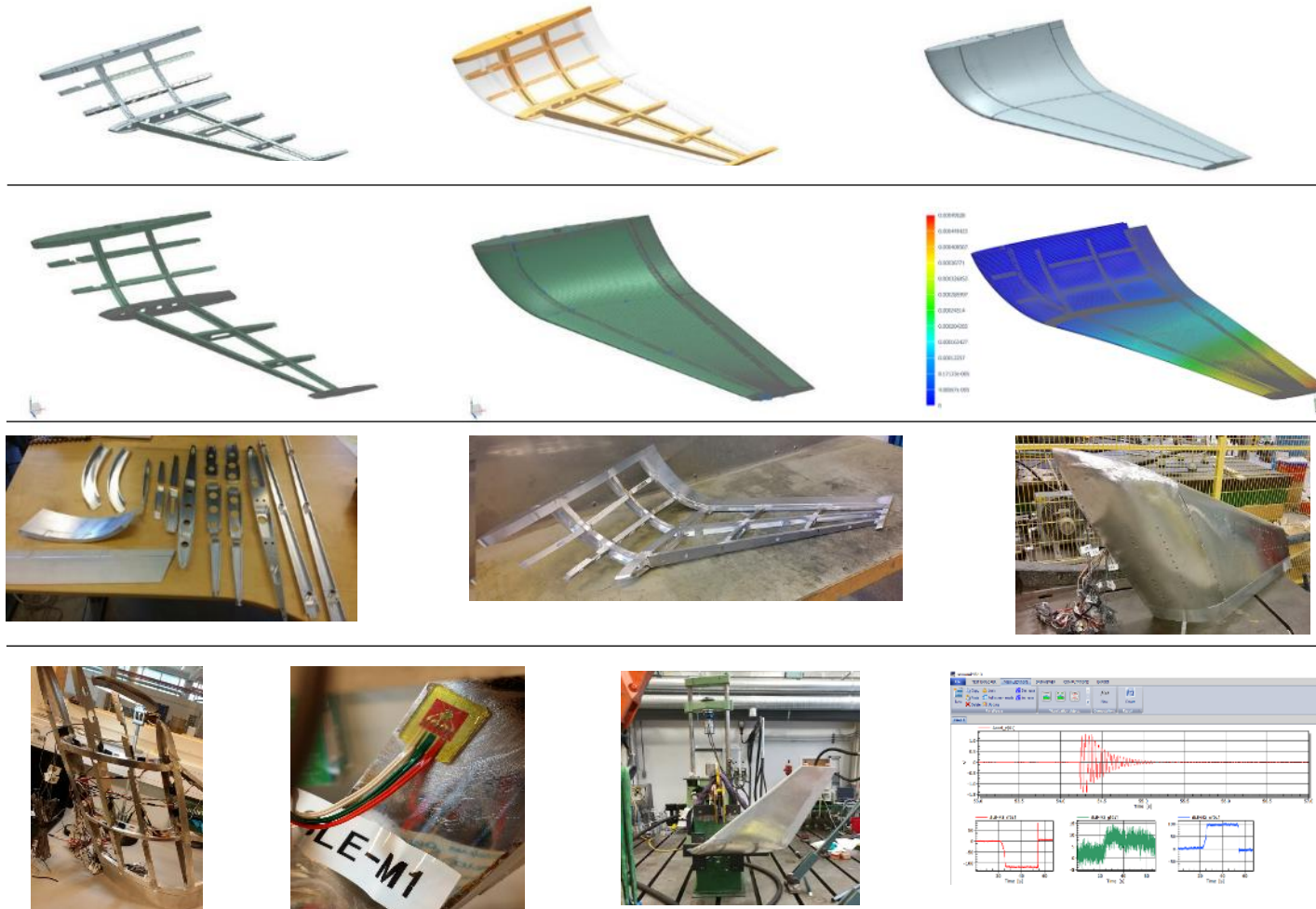

PhD thesis

- *Improving and implementing the STEP ISO 10303 standard for design, analysis and structural test data correlation*
- Paper in *Advances in Engineering Software*:
<https://www.sciencedirect.com/science/article/pii/S0965997818301947>
- Two more papers under review

Together with Lockheed Martin (Crystal Project):

- Winglet prototype design by Lockheed Martin
- Produced at NTNU
- Analyzed (FEA)
- Mounted sensors and set in test rig
- FEA load cases tested physically
- Design (CAD) → AP209
- Simulation data → AP209
- Structural Test data → AP209
- All data managed in AP209 in Jotne's SDM tool (EDMopenSimDM)
- All traceability kept

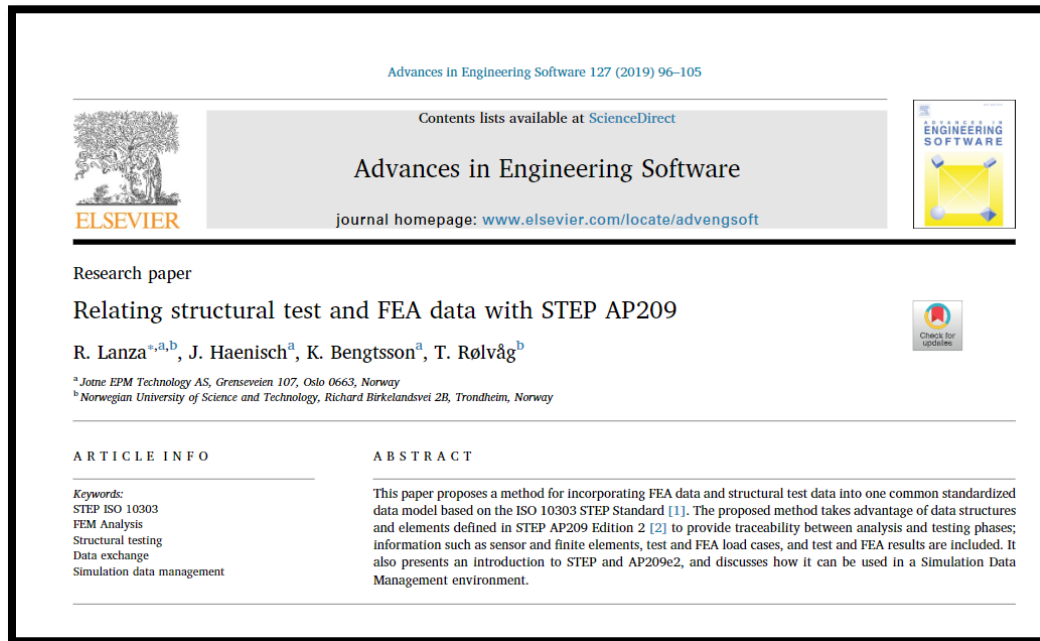

Advances in Engineering Software 127 (2019) 96–105

Contents lists available at ScienceDirect

ELSEVIER

Advances in Engineering Software

journal homepage: www.elsevier.com/locate/advengsoft

Research paper

Relating structural test and FEA data with STEP AP209

R. Lanza^{a,d}, J. Haenisch^a, K. Bengtsson^a, T. Rølvåg^b

^a Jotne EPM Technology AS, Grenseveien 107, Oslo 0663, Norway
^b Norwegian University of Science and Technology, Richard Birkelandsvei 2B, Trondheim, Norway

ARTICLE INFO

Keywords:
 STEP ISO 10303
 FEM Analysis
 Structural testing
 Data exchange
 Simulation data management

ABSTRACT

This paper proposes a method for incorporating FEA data and structural test data into one common standardized data model based on the ISO 10303 STEP Standard [1]. The proposed method takes advantage of data structures and elements defined in STEP AP209 Edition 2 [2] to provide traceability between analysis and testing phases; information such as sensor and finite elements, test and FEA load cases, and test and FEA results are included. It also presents an introduction to STEP and AP209e2, and discusses how it can be used in a Simulation Data Management environment.

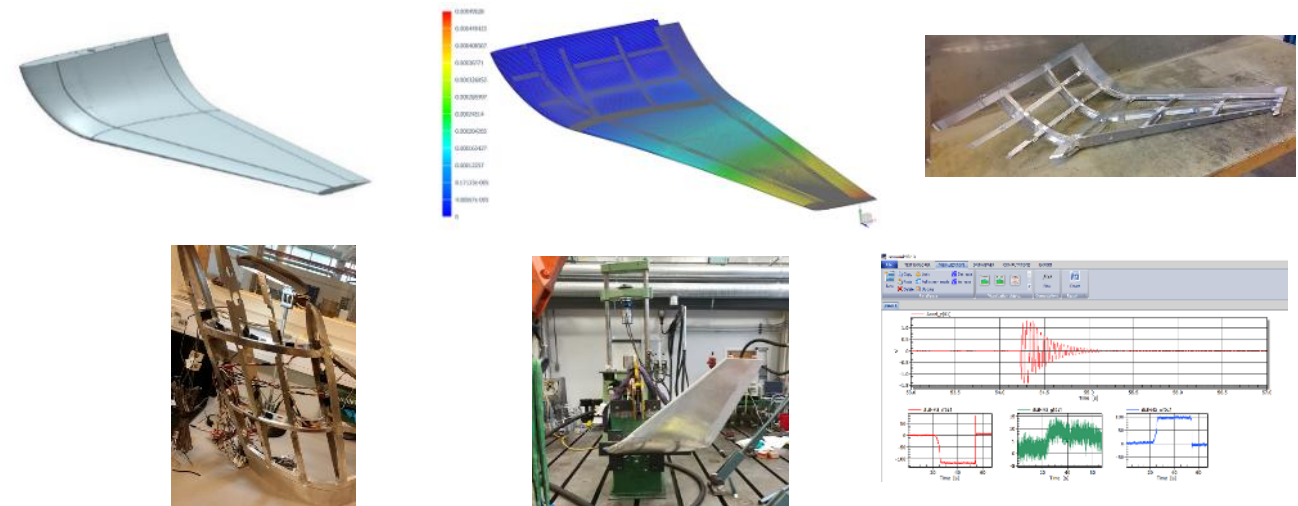

AP209 edition 3: Work in ISO (1/2)

- No change in scope
- Include AP242 edition 2
- Collector bug BZ#6199 lists all issues to be resolved by edition 3.
- Among others, these BugZilla issues are included:
 - 3537: Extended enumeration mismatch
 - 4099: maths_space assigned to incompatible types
 - 4862: Add isogeometry to part 50
 - 4992: Patch 409, 410 mim longforms to add 209, 210 specific ap rule and remove ap242 specific ap rule
 - 4993: add application_protocol_definition rule to 409 mim shortform
 - 5018: Function stripped_typeof needs to distinguish simple data types
 - 5019/5021/5047: Maths_value WHERE-rule: invalid parameter
 - 5022: AM409 should include a CFD usage guide
 - 5023: Entity mesh_derived_math_space shall be a tuple_space
 - 5027: Parallel_composed_function.final_function: mismatch with derive_function_range
 - 5045: Entity mesh_derived_math_space shall be a tuple_space
 - 5048/5049: P110 only handles one-dimensional components of 3-dimensional properties
 - 5052: Patch 409 MIM_LF - Type mismatch in call of make_extended_tuple_space
 - 5054: Update function is_coordinate_property for BZ#5048
 - 5054/5055: Update function is_coordinate_property for BZ#5048
 - 5075/5076/5077: broken link in mathematical_functions_schema.htm
 - 5514: TYPE element_order: upward incompatible name changes
 - 5659: maths_value.WR name inconsistent with WG12 methodology
 - 5681: AP209 mapping errors not addressed in CR11
 - 5706: Correct Manufacturing_configuration.WR2 for string replacement problem
 - 5928: Cylindrical_point, Spherical_point and Polar_point are missing in the AM409 longform
 - 5928/5516: Cylindrical_point, Spherical_point and Polar_point are missing in the AM409 longform
 - 6008: Groupable_item
 - 6025: Error in rule subtype_mandatory_shape_representation
 - 6026: Error in founding evaluation in Geometric_representation_item.WR1
 - 6027/7321: Structural_response_representation_schema: Founding of fea_parametric_point; a FPP cannot have GRC and PRC at the same time.
 - 6079: Conflicts in uses of application_protocol_definition in AP209 and AP242
 - 6198: Correct WR1 in Parametric_Curve_3d_Element_Coordinate_Direction
 - 6425: Add named_unit_variable to the MIM to represent Fahrenheit
 - 6426: Enable Data_environment to point to a specification
 - 6522: Insertion patches applied to CR_designAPs_2 MIM long forms schema
 - 6524: Manage insertions in the 442 MIM to prevent future re-insertion patches
 - 6642: Manage insertions in the 409 MIM to prevent future re-insertion patches
 - 6660: function consistent_topological_reference references a non-existent type

AP209 edition 3: Work in ISO (2/2)

- Bugfix version:

Resolution 964: (Jeju – November 2017)

Approve a NP to create a new edition 3 of ISO 10303-209

SC 4 approves a NP to create a new edition 3 of ISO 10303-209 with the same scope as ISO 10303-209 edition 2 “Multidisciplinary analysis and design”, using SDT48, with Jochen Haenisch as the project leader.

- Schedule:

| Milestone | latest on |
|---|------------|
| Start | 2017-11-21 |
| First working draft available on ISOeCommittees | 2018-11-21 |
| Include AP242ed2 | 2019-06-12 |
| CD ballot initiated by SC 4 Secretariat | 2020-02-21 |
| DIS document accepted for ballot by ISO | 2020-11-21 |
| DIS ballot registered for formal approval (if DIS required) | 2021-03-21 |
| Publication by ISO | 2021-11-21 |

- Dependencies:

- AP242ed2: is included in its totality
- IR 10303-50, 52, 104, 107, 110: need bug fixes
 - Issue: 10303-50, 52, 104 and 110 are LATEX documents

- Status:

- Stepmod modules EXPRESS representations and mapping issues corrected.
- AP209 document built successfully on stepmod (locally).
- Support by Metanorma to convert Latex sources (P50, 52, 104 and 110) to Word.
- Updating of text documents is on-going.

AP209 edition 3: Recommended practices (1/4)

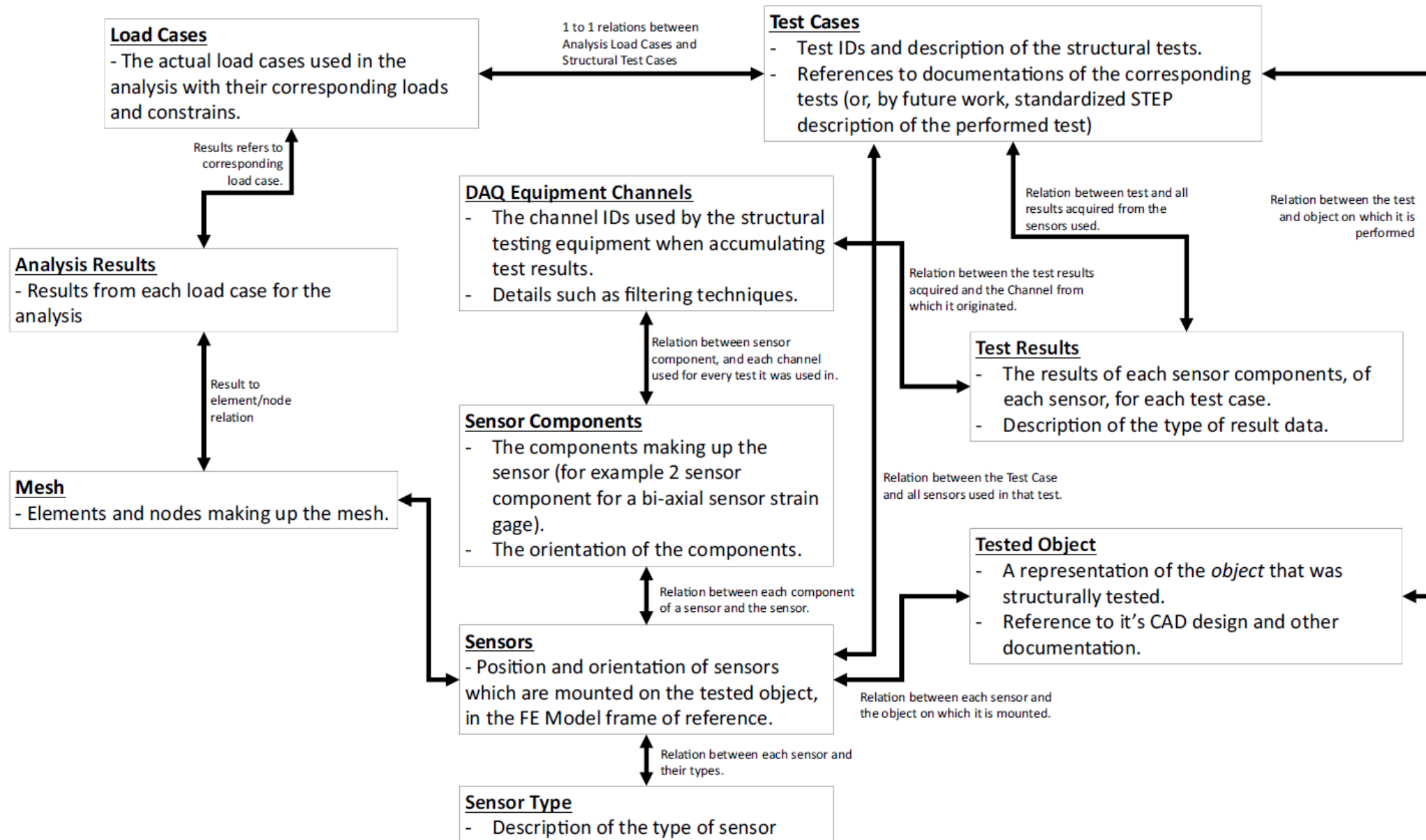

AP209 edition 3: Recommended practices (2/4)

- Additional request:
 - Define how to represent MPC and interpolation type elements such as NASTRANs **RBE2** and **RBE3**.
 - Temporary, but not perfect solution on next slides.
 - Images for reference:

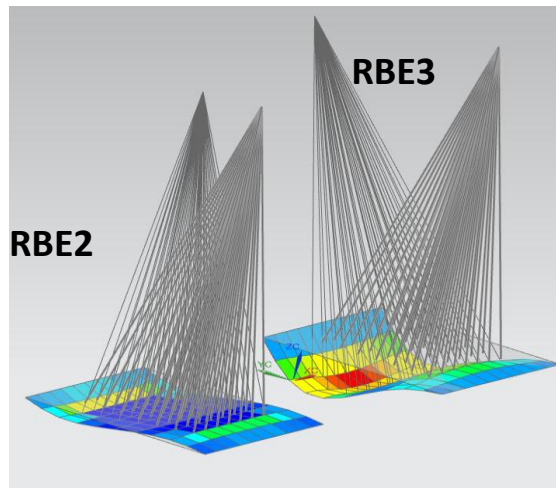

VM STRESS

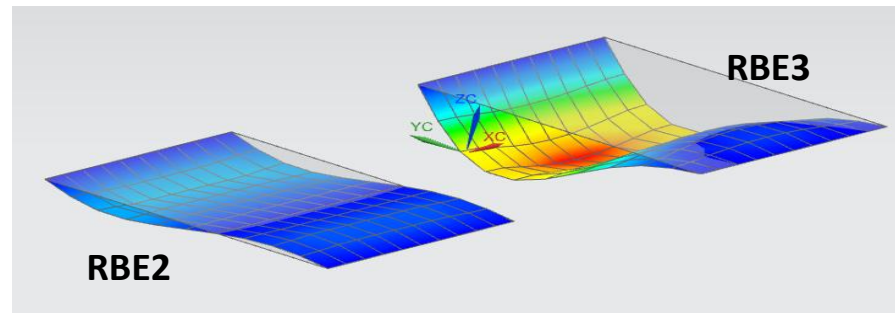

Displacement

AP209 edition 3: Recommended practices (3/4)

LINEAR_CONSTRAINT_EQUATION_ELEMENT

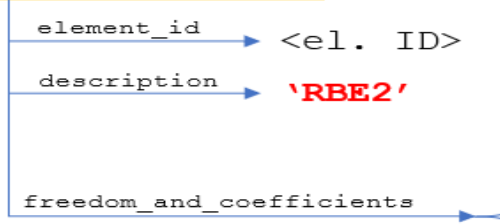

LINEAR_CONSTRAINT_EQUATION_NODAL_TERM

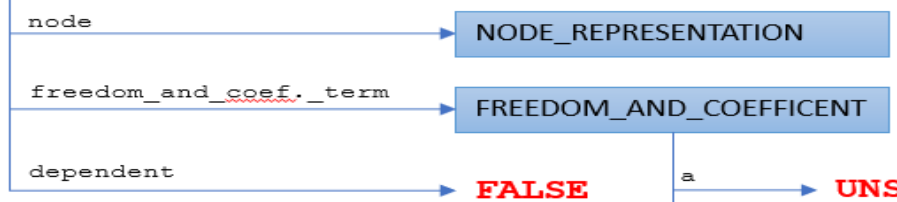

LINEAR_CONSTRAINT_EQUATION_NODAL_TERM

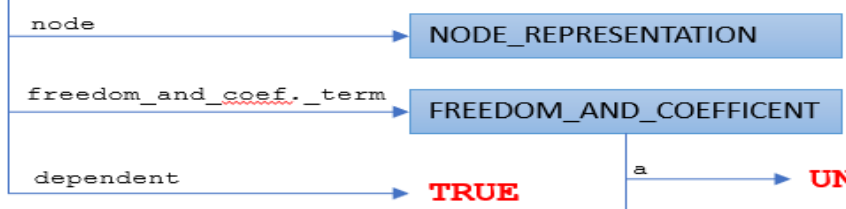

RBE2

independent DOFs

RBE2

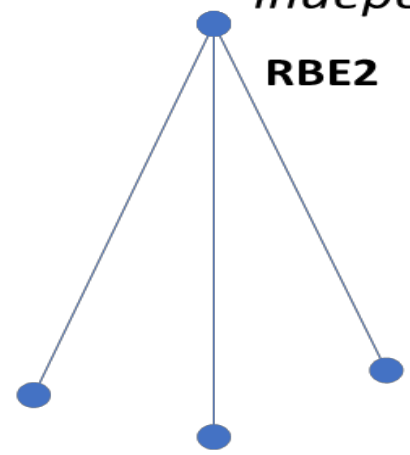

dependent DOFs

AP209 edition 3: Recommended practices (4/4)

LINEAR_CONSTRAINT_EQUATION_ELEMENT

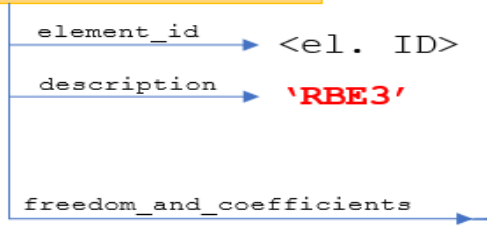

LINEAR_CONSTRAINT_EQUATION_NODAL_TERM

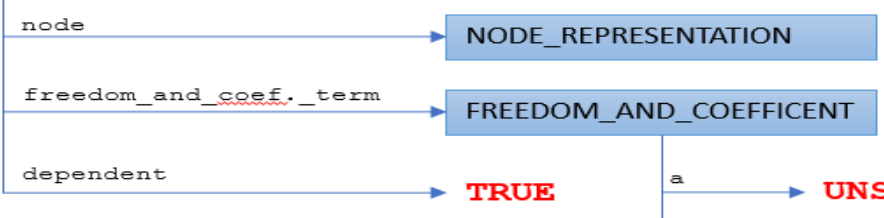

LINEAR_CONSTRAINT_EQUATION_NODAL_TERM

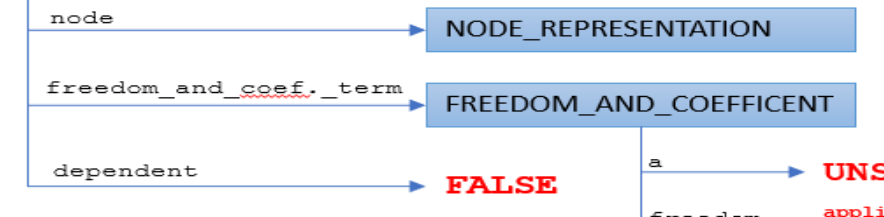

RBE3

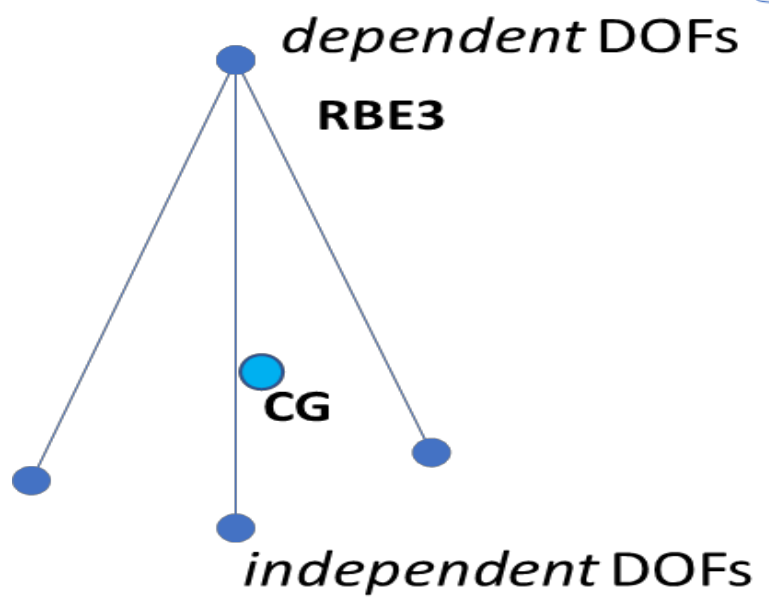

AP209 edition 4 (1/5)

Jotne prepared a request for interest:

- ISO/TC 184/SC 4/WG 12 N9325
 - Invitation to ISO 10303-209 edition 4
- Was distributed by SC 4/WG 12, LOTAR and PDES
- Proposed scope items
 - Structural and aeroelastic testing
 - Simulation related workflow instructions and feedback
 - Systems engineering and product data management context
 - Isogeometric design and analysis (WG12 N8354)
 - Binary files implementation method (CGNS/HDF5)
 - Discrete Element Method (DEM)
- Review by LOTAR EAS etc. urged to give priority to
 - Non linear geometry structural FEA
 - Non linear material structural FEA

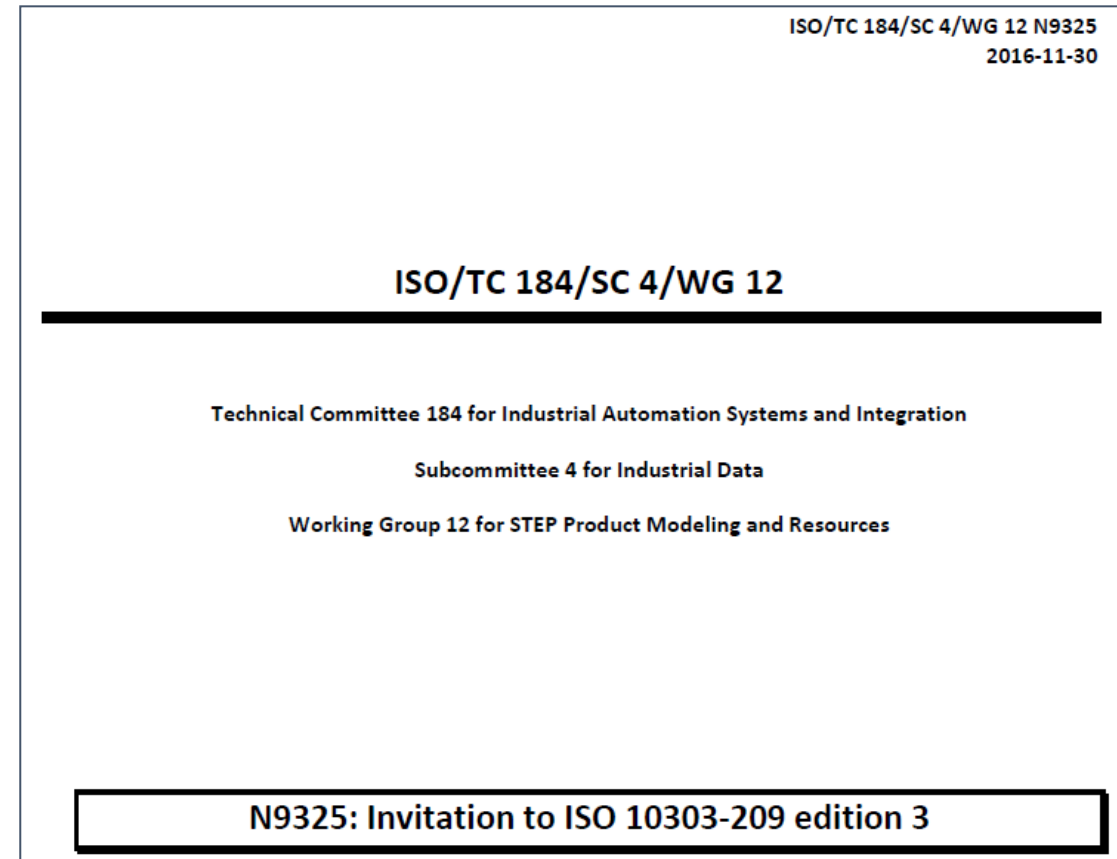

AP209 edition 4 (2/5)

- Isogeometric analysis:
 - SINTEF in Norway has started to edit the module “Extended b spline geometry”, supported by Jotne. A draft of the ARM was distributed to all WG12-experts for comments.

AP209 edition 4 (3/5)

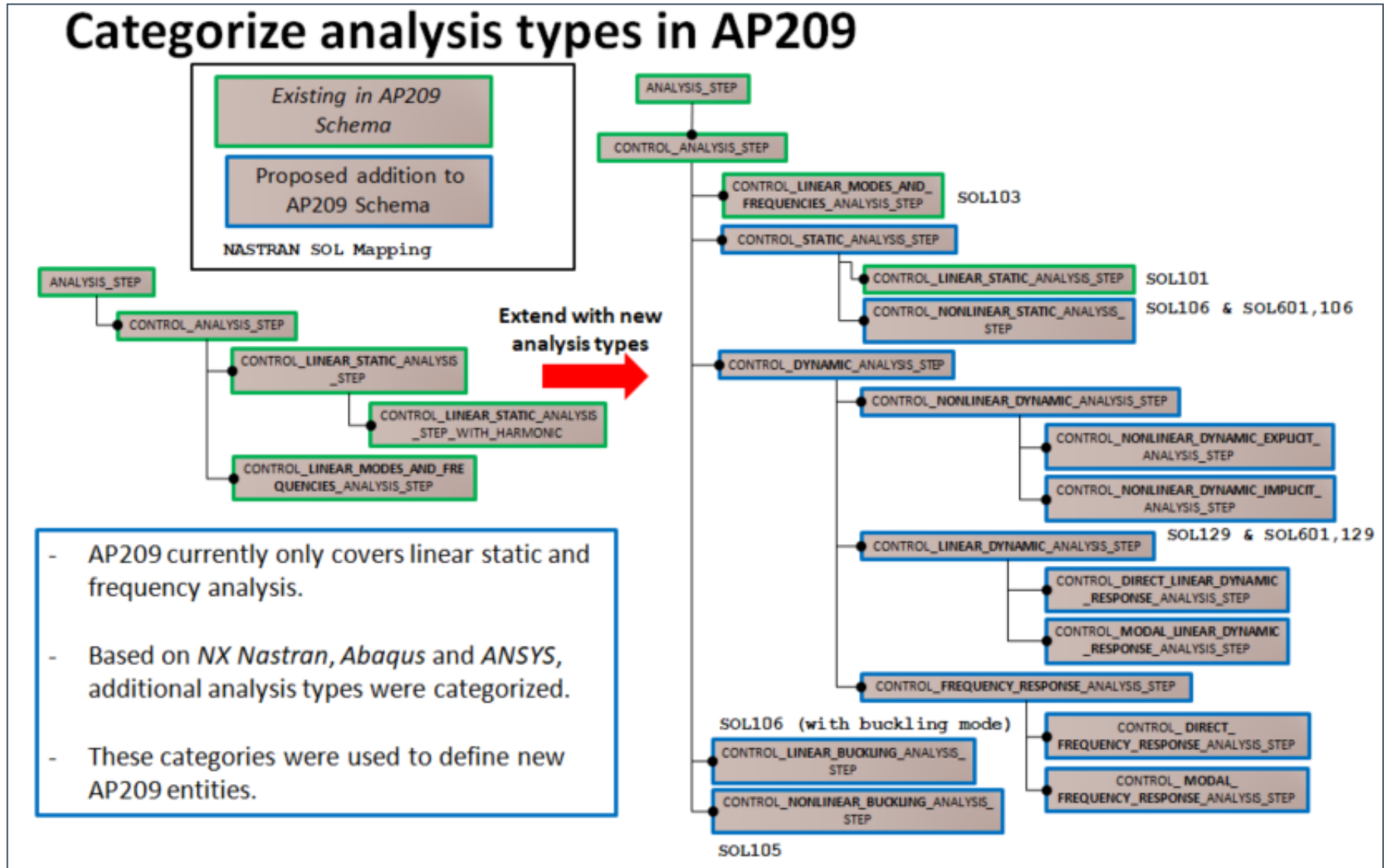

AP209 edition 4 (4/5)

Test Cases used in the study:

Test A

- Shell elements
- NL Static
- Pressure load over surface
- Fixed increment size

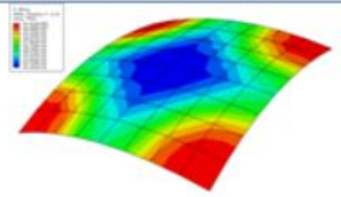

TEST A - ABAQUS

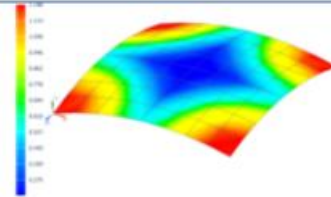

TEST A - NASTRAN

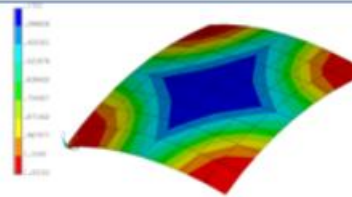

TEST A - ANSYS

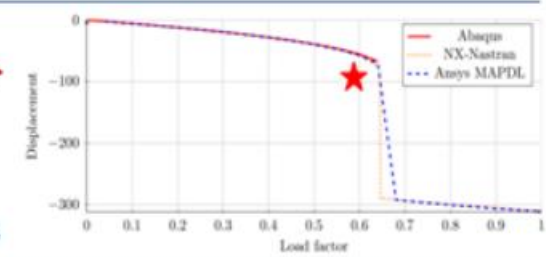

Test B

- Shell elements
- NL Static
- Pressure load over surface
- Arclength control

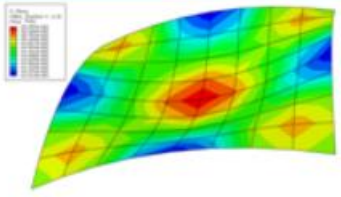

TEST B - ABAQUS

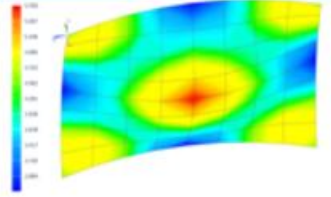

TEST B - NASTRAN

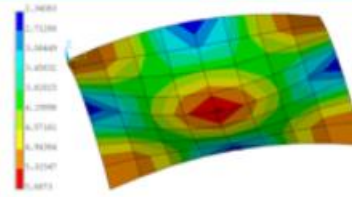

TEST B - ANSYS

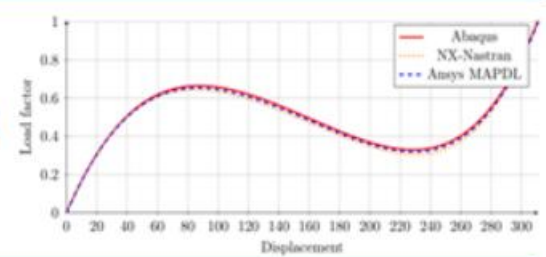

Test C

- Volume elements
- NL Dynamic
- Impulse load at beam end point defined by table
- Rayleigh damping
- Specified initial / min / max increment sizes

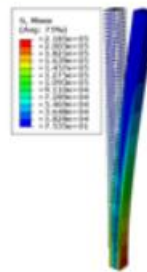

TEST C - ABAQUS

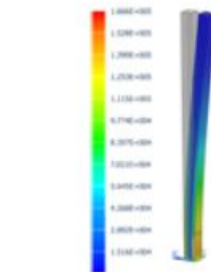

TEST C - NASTRAN

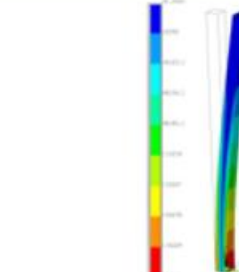

TEST C - ANSYS

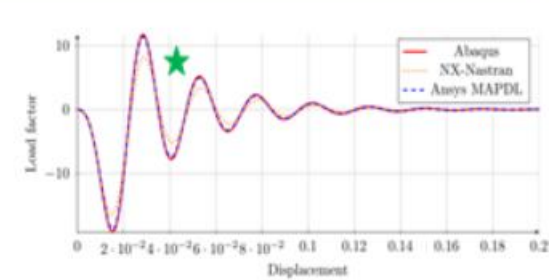

NOTE: The results on the mesh is the VM misses stress (at shell bottom surface for A & B).

NOTE: Each tests were created in Abaqus then converted to AP209. From AP209 they were converted to Ansys and Nastran.

★ Buckling happens here. In Abaqus Line search is **off** by default, in NX Nastran & Ansys it is **on**. This seem to be why Abaqus stops, while NX and Ansys steps through it.

★ NX Nastran has slightly different results. The cause for this has not been found yet.

AP209 edition 4 (5/5)

Introduce analysis/solver parameters for non-linear analysis to AP209

Category: `increment_parameters`

Analysis parameters:
`start_time`
`end_time`
`fixed_increment_size`
`initial_increment_size`
`min_increment_size`
`max_increment_size`
`fixed_increment_number`
`initial_increment_number`
`min_increment_number`
`max_increment_number`

Category: `iteration_parameters`

Analysis parameters:
`max_iterations_per_increment`
~~`min_iterations_per_increment`~~
`iterations_before_stiffness_update`
`update_stiffness_at_first_iteration`

Category: `arc_length_method_parameters`

Analysis parameters:
`min_arc_length`
`max_arc_length`
`min_arc_length_adjustment_ratio`
`max_arc_length_adjustment_ratio`
`min_arc_length_adjustment_ratio_to_initial`
`max_arc_length_adjustment_ratio_to_initial`
`load_scaling`
`method`

Category: `large_displacements`

Analysis parameters:
`use_large_displacements`

Category: `damping_parameters`

Analysis parameters:
`constant_rayleigh_stiffness_matrix_term`
`constant_rayleigh_mass_matrix_term`

Category: `line_search_parameters`

Analysis parameters:
`use_line_search`
`...`

Category: `convergence_criteria`

Analysis parameters:
`tolerance_variable`
`tolerance_value`

- AP209 currently doesn't have any concept of analysis or solver parameters and settings.
- Based on *NX Nastran*, *Abaqus* and *ANSYS*, common analysis parameters were identified.
- These were categorized, and mapped to the AP209 standard.

Digital Twin Based Crane Monitoring

Digital Twin: As simulated

In Operation

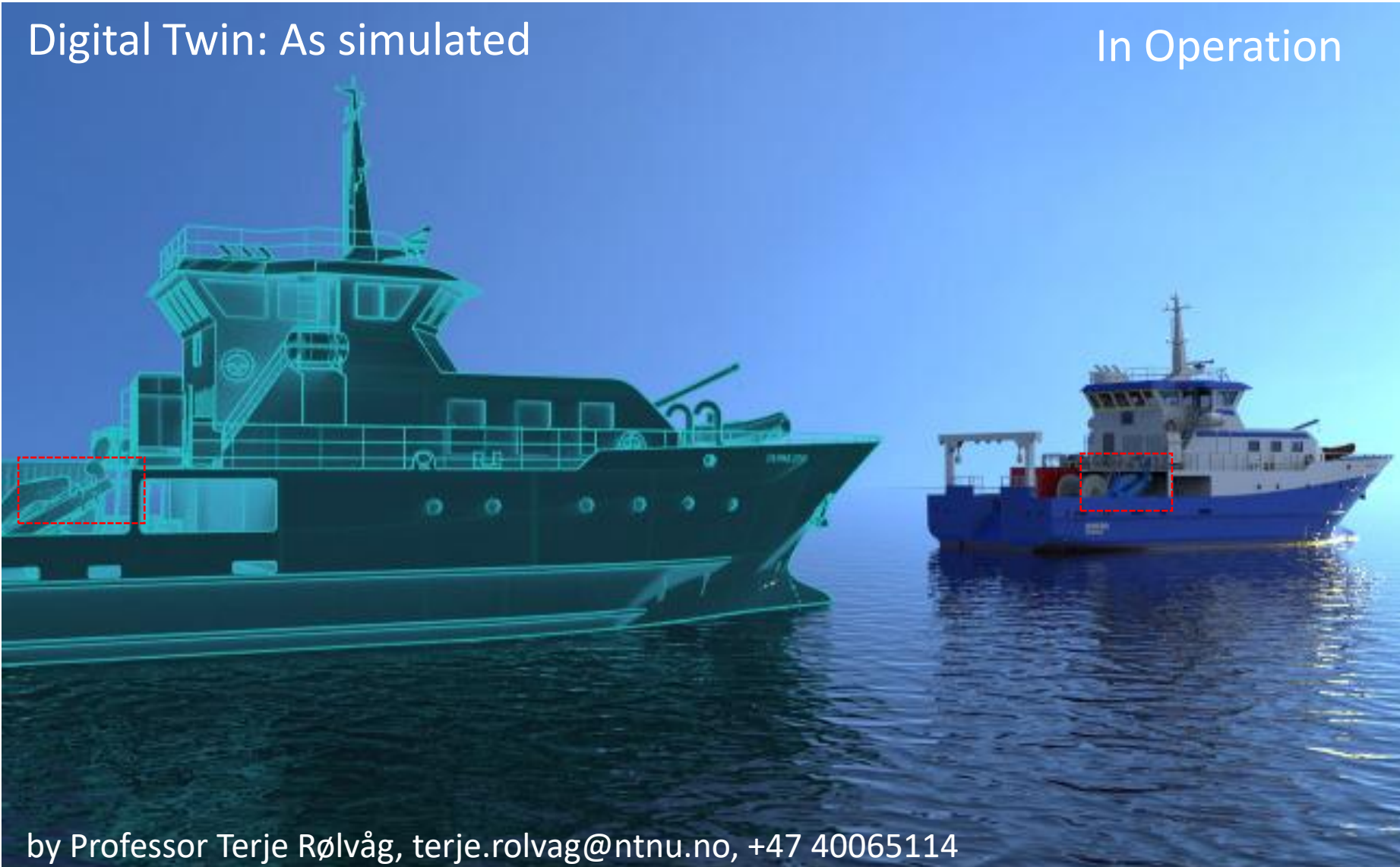

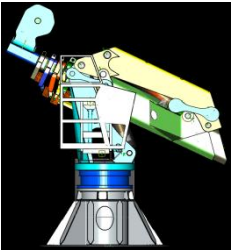

Palfinger Crane Monitoring

Based on a validated FEDEM Digital Twin (DT) model

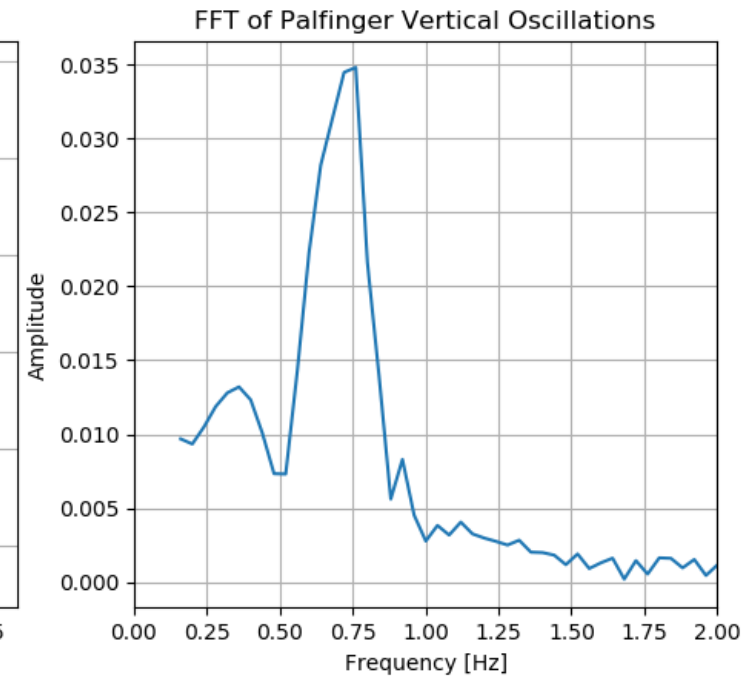
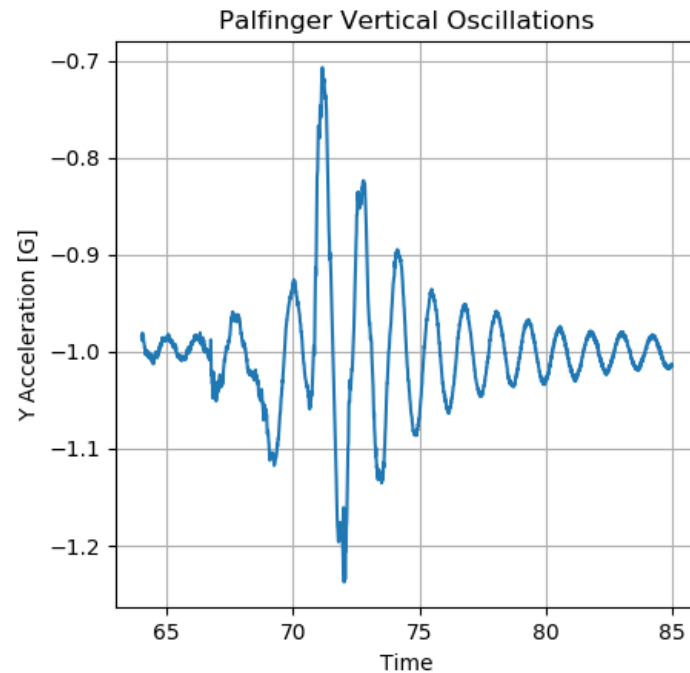

Digital Twin FEA technology

Our Digital Twin models are simulated in real time by FEDEM:

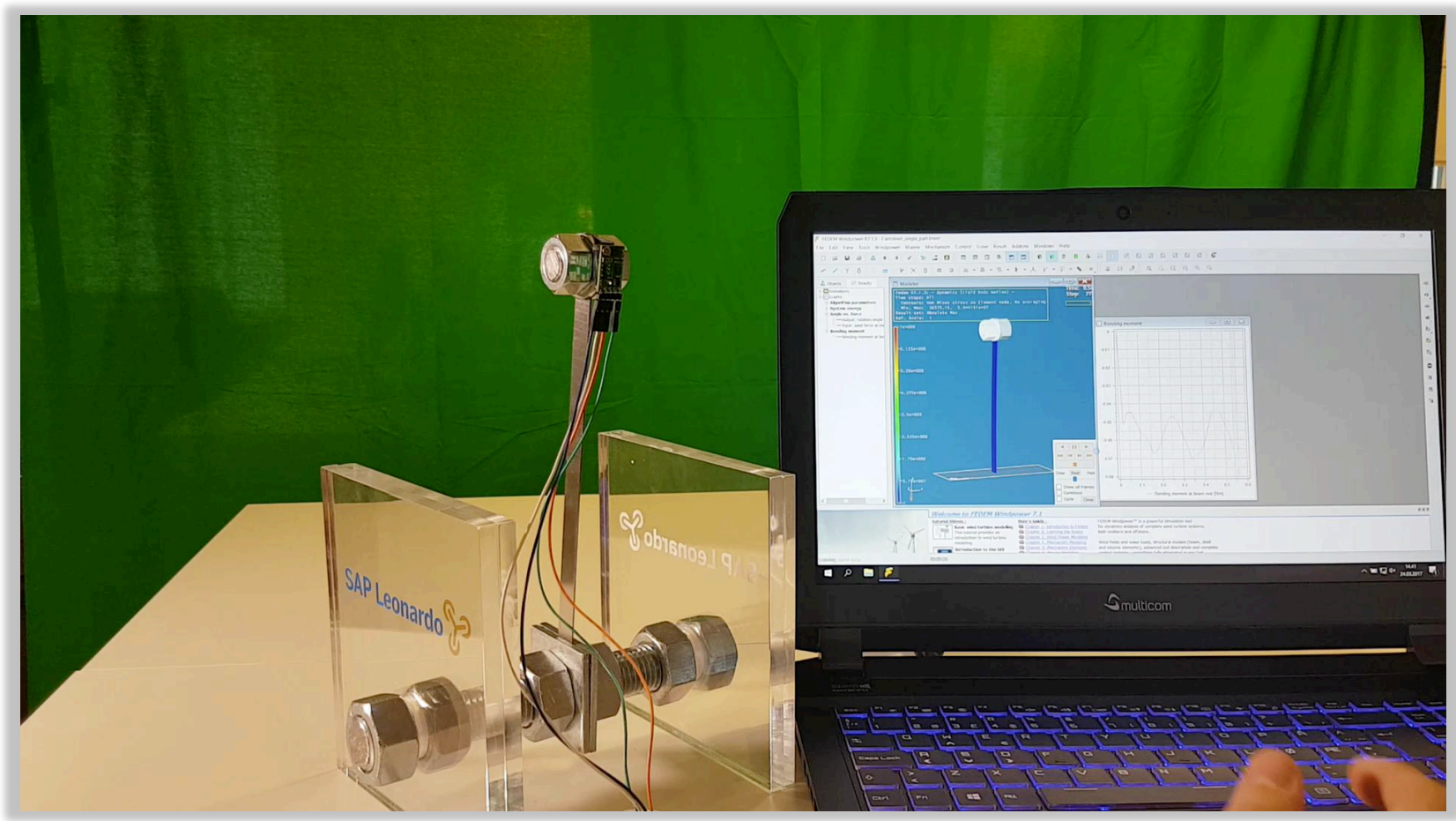

Digital Twin FEA technology

Our Digital Twin models are simulated real time in FEDEM:



Mesh too dense
to be shown
(3.6 mill DOFs)

- CAE
 - 3D modelling / idealization
 - Joint / spring / damper / sensor modelling
 - Substructuring (25 super elements)
 - Meshing
- Dynamic simulation (nonlinear FEA)
 - Forces, Positions, Velocities and Accelerations
- Structural Analysis
 - Stresses / strains
 - Vibration frequencies
 - Damage / durability
- Control / hydraulics
 - PI / PD / PID Controllers
 - Closed loop dynamics

$$M(r, t) \ddot{r}(t) + C(r, \dot{r}, t) \dot{r}(t) + K(r, t, \sigma) r(t) = F(t)$$

$$\epsilon_{rosette} = [T_{re} \tilde{B} T A L H] v_{sup}$$